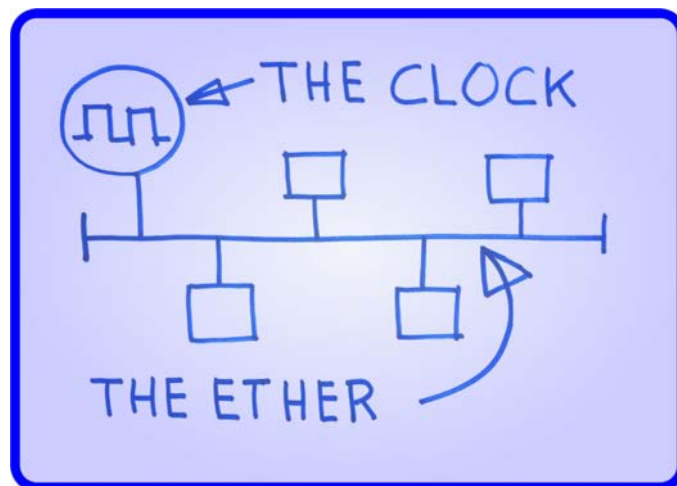

Application Note

Number 20/2009

Created: December 14, 2009

Last modification: -

Synchronization Networks Based on Synchronous Ethernet



1 Introduction

Telecommunication networks are evolving from TDM networks based on circuit-switched technology to so-called Next Generation Networks (NGN) based on packet-switching. The driver of this evolution is cost reduction; the technical goal is the transport of all telecommunication services over a unified and packet-switched platform. Ethernet is already playing an important role in the network convergence scenario. Ethernet started as a LAN technology for enterprise networks, and is now being used in base station backhaul and aggregation networks, and even in metro networks. It turns out that many access network technologies require some form of synchronization. This is the case for all cellular mobile networks which require their base stations to be synchronized. There are other cases like some of the PON technologies. Some of these technologies require synchronization of their equipment clocks in frequency, some in phase. A useful overview of these synchronization needs can be found in a draft IETF document called "TICTOC Requirements" [6], as well as in Appendix IV of ITU-T Recommendation G.8261 [1]. Traditional Ethernet is not designed for the transport of synchronization. Therefore the use of Ethernet in aggregation and backhaul networks is problematic for all access technologies in need of synchronization. The answer to the problem for the case of frequency synchronization is Synchronous Ethernet (SyncE). Simply put, SyncE is traditional Ethernet plus a synchronization transport function similar to that in SDH and SONET. SyncE enables the transport of frequency synchronization. SyncE was standardized by the ITU-T in cooperation with IEEE. ITU-T recently published the three new recommendations dealing with SyncE. ITU-T Rec. G.8261 addresses (among other things) the architecture and the wander performance of SyncE networks. G.8262 specifies an equipment clock for SyncE, and G.8264 contains the specification of a synchronization signaling channel called the ESMC (Ethernet Synchronization Messaging Channel).

2 How Does SyncE Work?

In Synchronous Ethernet, frequency is transferred over a communication link simply as the timing of the bits (or moments) on the line. This presupposes that the transmitting port transmits continuously. Out of the many Ethernet physical signals standardized by IEEE only those with continuous transmission can be used in the context of Synchronous Ethernet. Figure 1 illustrates the principle. This is not new. The same transfer technique has been used in telecommunication for a long time, notably in synchronization based on E1/T1 and based on SDH/SONET.

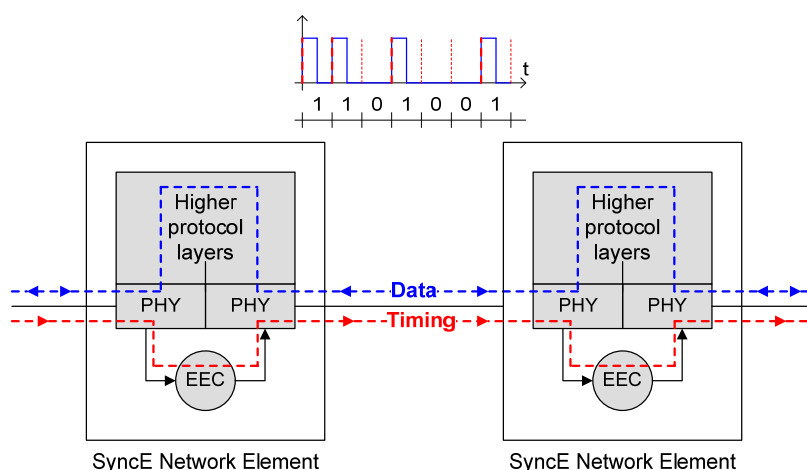

Figure 1: Frequency transfer over the physical layer

This mechanism for frequency transfer is used to build a tree of interconnected equipment clocks. At the root of the tree is the Primary Reference Clock (PRC). Each and every SyncE Network Element contains an internal clock called the Ethernet Equipment Clock (EEC). Normally the EEC is locked in frequency to one of its incoming traffic line signals, while all outgoing line signals are timed by the EEC (this is called the locked mode). This way a master-slave tree is built where synchronization travels from the PRC down all the clock

chains formed by the branches of EECs. Figure 2 shows such a master-slave tree. It is exactly the same architecture as with SDH/SONET-based synchronization.

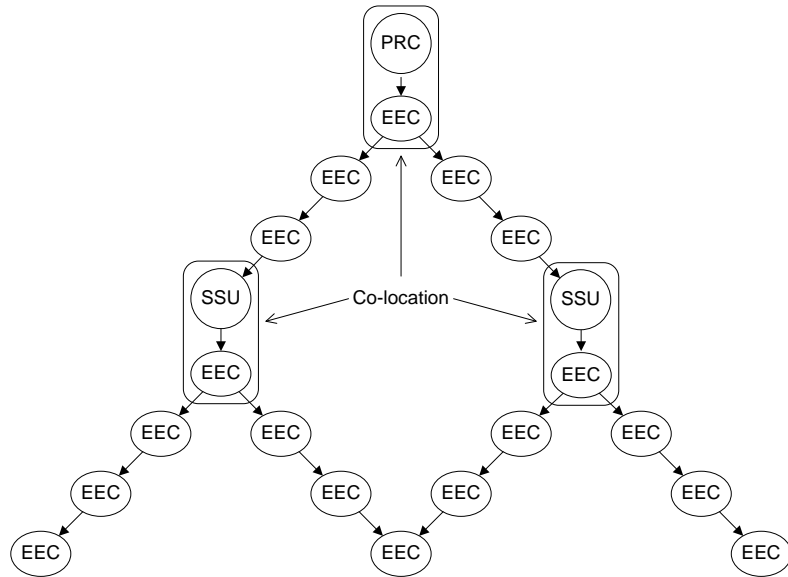

Figure 2: Inter-node distribution architecture

The figure also shows a third category of clocks called Synchronization Supply Unit or SSU. Like in SDH and SONET, SSUs are needed for three reasons. First they reduce the accumulated jitter and wander to levels which are compliant with the relevant limits. Secondly they act as a node clock, i.e. the central clock of a 'node' or telecom building. This node clock distributes synchronization to other equipment in the building. Finally, the SSU provides so-called holdover protection: when the traceability to the PRC is lost because of some failure, the SSU becomes an autonomous frequency source running on its internal oscillator, usually of the ovenized quartz or a Rubidium type. In holdover mode synchronization supply continues with a stability which, while not as good as in locked mode, allows the site to continue operating until the failure is repaired.

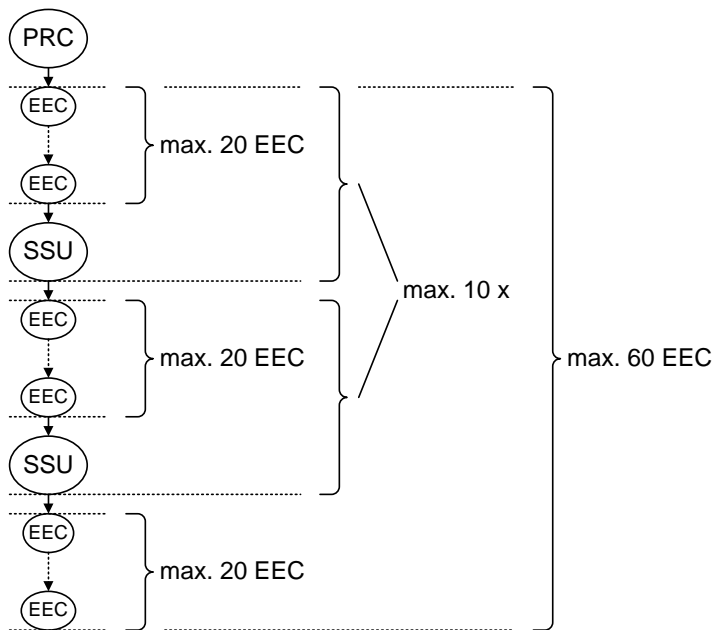

Figure 3: Synchronization reference chain for SyncE and SDH (ITU-T Rec. G.803)

The control of the level of jitter and wander is very important in SyncE networks. ITU-T Recommendations give a clear framework for this. So-called Network Limits specify the maximum acceptable jitter and wander for different classes of interfaces in the network. Network Limits for synchronization signals are specified in ITU-T Rec. G.823. ITU-T Recommendations don't stop there. They also give some design rules on how to achieve a synchronization network that complies with the just mentioned Network Limit specifications. The main set of rules is that of the so-called « synchronization reference chain », as specified in ITU-T Rec. G.803. This applies both to SDH and to SyncE. The first of three basically says that the synchronization signal should be regenerated by the insertion of SSUs or SASEs in the chain of clocks. There should never be more than 20 EECs or SECs between two SSUs or between the PRC and the first SSU. In practice operators tend to insert one SSU every 10 to 15 EECs or SECs, in order to have some margin in case the network grows or evolves. The « reference chain » model states two other rules, which will only come into play in fairly large networks. One rule says that there should not be more than 60 EECs or SECs in the entire synchronization chain. The third and last rule says that there should not be more than 10 SSUs in the chain. Strict application of these rules guarantee that the already mentioned Network Limit specifications are complied with, provided that the deployed clocks - PRCs, SSUs, EECs and SECs - comply with the relevant ITU-T specification (it goes without saying that this is the case for all Oscilloquartz equipment).

3 Synchronization Signaling

In SDH and SONET there is a synchronization signaling system known as the Synchronization Status Message or SSM. The SSM is a message contained in the multiplex layer overhead. It carries an information about the quality level of the source clock from clock to clock along the branches of the synchronization distribution tree. The source clock is either the PRC (normal condition) or another clock in holdover mode (failure condition). There are a number of pre-defined quality levels (QL) corresponding to existing clock specifications i.e. QL-PRC, QL-SSU-A, QL-SSU-B, QL-SEC and QL-DNU. The last message means 'Do Not Use'. This signaling system is used for controlling protection switching in case of link or clock failures. This SSM system also exists in Synchronous Ethernet. It works in exactly the same way as in SDH and SONET. The only difference is the communication channel used for transferring the SSM from clock to clock. In SDH and SONET the SSM is contained in the SSM Byte (SSMB) of the STM-n or OC-n frame overhead. Synchronous Ethernet uses the so-called 'Ethernet Synchronization Messaging Channel' or ESMC. It consists of special Ethernet frames. The format of the ESMC messages is described in Annex A. The important point to note here is that there is a perfect continuity between SDH and SONET on side, and Synchronous Ethernet on the other.

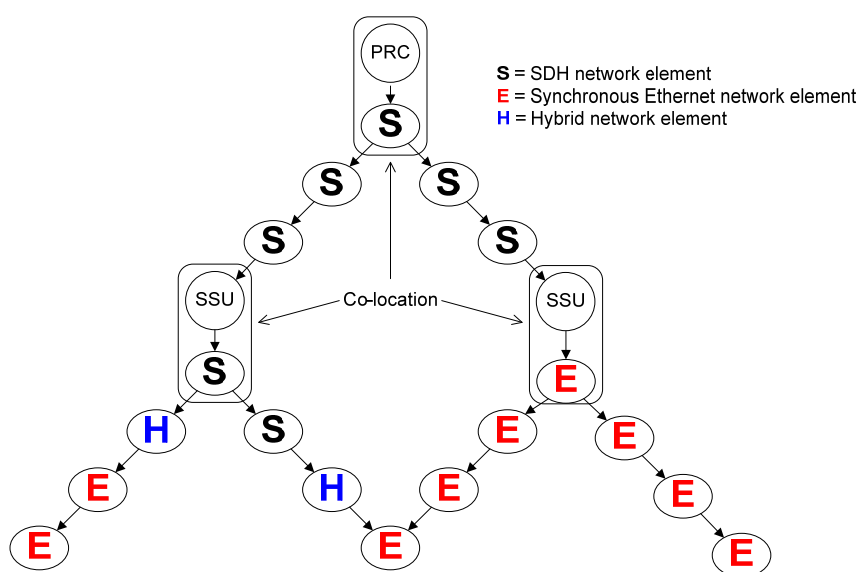

Figure 4: Mixed architecture

4 Mixing SyncE and SDH/SONET Networks

In real-world networks, Ethernet and SDH/SONET are often mixed. For example, an operator might be using SDH or SONET in the core network, and Ethernet in the aggregation network. At the border between the SDH/SONET and the Ethernet parts there are hybrid network elements. These feature SDH interfaces with the corresponding VC cross-connecting function as well as Ethernet interfaces with the corresponding packet (frame) switching. In case the Ethernet network elements and the Ethernet interfaces are of the Synchronous Ethernet type, they can be mixed with the SDH/SONET network elements to form one unified synchronization network. This is possible because the EEC specification is identical with the SEC specification, and because ESMC conveys the same information as the SSM.

5 Synchronization Solutions Based on SyncE

Figure 4 shows a typical application of the use of SyncE. The diagram shows a mobile network where the base stations (or Node Bs) are connected via a Synchronous Ethernet network. Base stations always require some form of synchronization. With some technologies, e.g. GSM, UMTS and WiMax-FDD, frequency synchronization is all that is needed (other technologies such as cdma2000 and WiMax-TDD require phase synchronization).

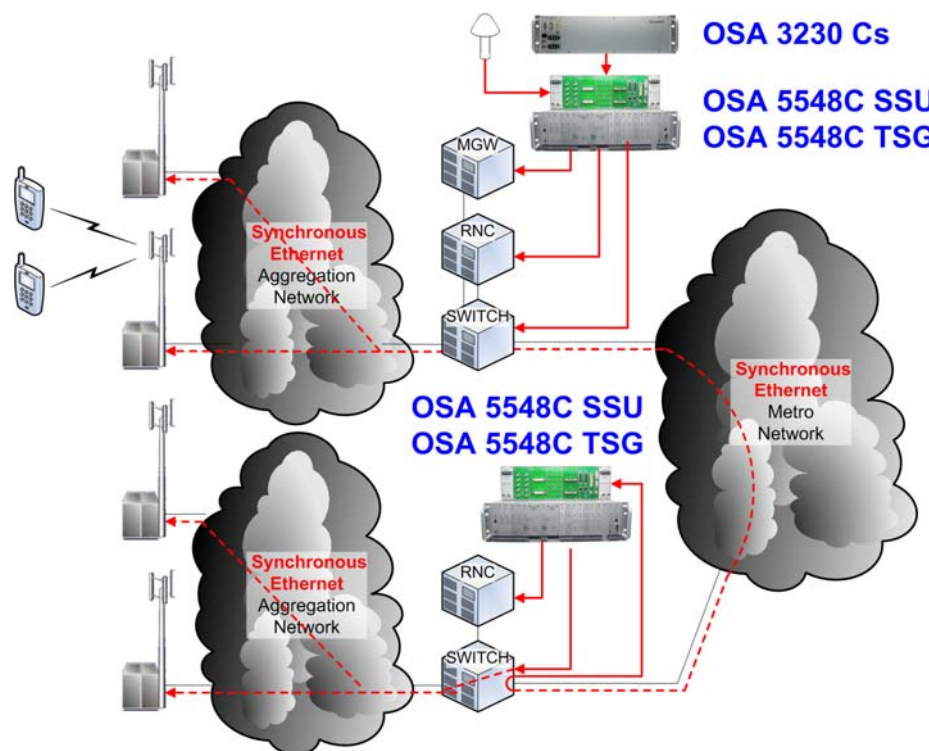

Figure 5: Application example

In the frequency synchronization case Synchronous Ethernet is an ideal solution. It combines the cost-effectiveness of Ethernet with the synchronization distribution capability of SDH. The advantage, compared to standard Ethernet, is that the base stations can now be synchronized through the network. The alternative would be to install GNSS-receivers and -antennas (GPS, Glonass, etc.) in all base station sites. The figure shows the major network element categories of a WCDMA network: MGW, RNC and Node B. Other mobile technologies have very similar architectures, except that the network element categories have different names (in GSM we have MSCs instead of MGWs, BSCs instead of RNS and BTSs instead of Node Bs, etc.). All of them require synchronization. One of the MGW/MSC sites is usually the PRC site. In the figure the PRC is made of an atomic Cesium Clock (type OSA 3230 Cs) and an SSU with integrated GPS-receiver module (type OSA 5548C SSU or OSA 5548C TSG). The 5548C SSU is the ETSI version of the product, whereas the 5548C TSG is the ATIS/Telcordia version. Combining an atomic Cesium clock with a GPS-receiver as two reference sources of a PRC has two advantages. The availability figure is increased because there are multiple frequency sources (redundancy). Robustness against failures is increased even more because of the use of completely different technologies. These technologies have completely different potential failure modes.

In the PRC site the outputs of the SSU or TSG feed the MGW, the RNC and the Ethernet switch with synchronization using traditional 2.048 MHz, 2.048 Mbit/s, 1.544 Mbit/s. or 64 kbit/s CC signals. The Node Bs (base stations) get synchronization through the aggregation network. Path redundancy is possible if the topology of the network allows it. Synchronization is also transported to other RNC sites like the one in the lower right corner of the diagram. Here an OSA 5548C SSU/TSG provides the necessary jitter and wander regeneration as well as holdover protection. The diagram shows how synchronization is extracted from the Ethernet traffic signal by the switch, then sent to the SSU/TSG; the outputs of the SSU/TSG then synchronize all network elements in the site, in particular the RNS and the Ethernet switch.

Protection switching is controlled by the ESMC. The SSU/TSG may or may not be part of the ESMC scheme. This depends solely on the signal type used to interconnect the SSU/TSG with the Ethernet switches. If the signals are of the 2.048 Mbit/s or 1.544 Mbit/s type, then the SSU/TSG is included in the ESMC path; the Ethernet switch translated the ESMC into SSM and the SSM back into ESMC. If the signals are of the 2.048 MHz or 64 kbit/s CC type, then the handling of the ESMC will be done at the switch level. It uses the Forced Quality Level and the Conditional Squelching features in the same way as in SDH/SONET.

The most important point to note here is the fact that the entire Oscilloquartz product line for SDH & SONET synchronization is fully compatible with Synchronous Ethernet. This is true not only for the two product types mentioned here, but also for all the others like the OSA 5240 GPS (a GPS-receiver), the OSA 5533C SDU (a synchronization distribution unit), and many more.

6 Conclusions

Synchronous Ethernet (SyncE) is an evolution of conventional Ethernet. In SyncE all Ethernet Equipment Clocks (EEC) are synchronized to Primary Reference Clock (PRC) which provides a fractional frequency accuracy of 1 part in 10^{11} . (in conventional Ethernet, the equipment clocks are free running with an accuracy of only 100 ppm). SyncE can be used as a synchronization distribution network for frequency. Frequency synchronization is required in many instances, e.g. for the operation of base stations and Node Bs in mobile networks. SyncE solves the problem of synchronization distribution in a packet-switched network context where traffic switching or routing is done in an asynchronous way. Synchronous Ethernet used the bit timing of the physical layer signal as the carrier for synchronization. In that respect it resembles SDH- and SONET-based synchronization. The similarity does not stop there. SyncE uses the same clock specifications as SDH/SONET. SyncE uses the Synchronization Status Message, just like SDH/SONET. SyncE network elements have the same synchronization input and output interfaces as SDH/SONET network elements. As a result the architecture of a synchronization network based on SyncE is the same as with SDH/SONET. It is even possible to build synchronization networks which are in part based on SyncE, and partly on SDH/SONET. Also, the same types of synchronization network elements, i.e. PRCs and SSUs, are used both in SyncE and in SDH/SONET. The Oscilloquartz product range for SDH and SONET synchronization is compatible with any synchronization network based on SyncE or a combination of SyncE and SDH/SONET.

7 Bibliography

- [1] International Telecommunication Union; *ITU-T Recommendation G.803: Architecture of transport networks based on the synchronous digital hierarchy (SDH)*; Geneva, Switzerland; March 2000.
- [2] International Telecommunication Union; *ITU-T Recommendation G.8261: Timing and synchronization aspects in packet networks*; Geneva, Switzerland; May 2006.
- [3] International Telecommunication Union; *ITU-T Recommendation G.8262: Timing characteristics of synchronous Ethernet equipment slave clocks*; Geneva, Switzerland; August 2007.
- [4] International Telecommunication Union; *ITU-T Recommendation G.8264: Distribution of timing through packet networks*; Geneva, Switzerland; October 2008.
- [5] J.-L. Ferrant et al.; *Synchronous Ethernet: A Method to Transport Synchronization*; IEEE Communications Magazine, Vol. 46, No. 9; September 2008.
- [6] Internet Engineering Task Force IETF, S. Rodriguez; *Internet Draft: TICTOC Requirements*; July 2009.

8 Abbreviations

Table 1: Abbreviations used in this Application Note

Cs	Cesium
EEC	Ethernet Equipment Clock
ESMC	Ethernet Synchronization Messaging Channel
IEEE	Institute of Electrical and Electronics Engineers
IETF	Internet Engineering Task Force
ITU-T	International Telecommunication Union, Telecommunication Standardization Sector
NGN	Next Generation Network
PRC	Primary Reference Clock
SDH	Synchronous Digital Hierarchy
SEC	SDH Equipment Clock
SONET	Synchronous Optical Network
SSM	Synchronization Status Message
SSU	Synchronization Supply Unit
SyncE	Synchronous Ethernet
TDM	Time Division Duplexing
TSG	Timing Signal Generator

Annex A: Ethernet Synchronization Messaging Channel (ESMC)

The ESMC is a communication channel for the Synchronization Status Message (SSM). The ESMC is based on an Ethernet protocol called 'Organization Specific Slow Protocol' (OSSP). There are two types of ESMC messages. The 'Information Message' is sent once per second; it acts like a heartbeat. The 'Event Message' is sent immediately after an event which causes the SSM value to change. Both message types convey the SSM. This system ensures a short reaction time despite the fact that the average message rate is around one message per second. A clock considers that the incoming ESMC is in failure condition if no 'Information Message' (heartbeat) has been received within a 5 second period. Table A.1 shows the format of the ESMC messages or PDUs (Protocol Data Units). Table A.2 shows the details of the 'Data and Padding' field of Table A.1. This field contains of the SSM. Table A.3 shows how future extensions can be added in the form of so-called TLV fields (Type-Length-Value).

Table A.1.: ESMC PDU format

Size	Field	Content (hex)
6 octets	Destination Address	01-80-C2-00-00-02
6 octets	Source Address	Port's MAC address
2 octets	Slow Protocol Ethertype	88-09
1 octet	Slow Protocol Subtype	0A
3 octets	ITU OUI ¹	00-19-A7
2 octets	ITU Subtype	01
4 bits	Version	01
1 bit	Event Flag	0 for Information PDU 1 for Event PDU
3 bits	Reserved	Reserved for future standardization
3 octets	Reserved	
36 to 1490 octets	Data and padding	See Table A.2
4 octets	FCS	Frame Check Sequence

Note 1: OUI = Organization Unique Identifier

Table A.2.: Details of the 'Data and Padding' field

Size	Field	Content (hex)
1 octet	Type	01
2 octets	Length	04
4 bits	Unused	0
4 bits	SSM	SSM code

Table A.3.: TLV format (for future extensions)

Size	Field	Content (hex)
1 octet	Type	...
2 octets	Length	...
N octets	Data and padding ¹	...

Note 1: Padding bits are added to ensure that the entire field is an integer number of bytes and a minimum of 64 bytes long.