Application Note

Number 14/2003

Created: May 2, 2003

Re-timing: Cost-effective Synchronization via Re-timed E1 and DS1 Signals



1 Introduction

Because of today's co-existence of data and voice traffic, and because of the emergence of more sophisticated mobile networks, modern telecommunication equipment almost always requires some form of synchronization. In today's de-regulated telecom environment, synchronization distribution has become a complex issue, since traffic signals often traverse the networks of several operators, thus traversing several synchronization domains. Interfacing problems affecting the quality of synchronization are almost inevitable. Synchronization problems can adversely affect business, since synchronization quality has a direct impact on quality of service as perceived by the end customer. Hence there is an impact on customer satisfaction and churn rate. This Application Note presents a family of solutions to synchronization interfacing problems. They are based on the synchronization of equipment via re-timed E1 and DS1 signals.

2 What is Re-timing?

Re-timing consists in "imprinting" the timing of an available synchronization signal onto a given traffic signal, usually an E1 or a DS1 signal. In the Re-timing function shown in Figure 1, the outgoing traffic signal contains the traffic data coming from the traffic input and the timing coming from the synchronization input¹. The outgoing traffic signal can now be used for synchronising other telecom equipment such as a switch or a base station.

Re-timing is useful in all situations, where there is no other way than taking a traffic-carrying E1/DS1 signal to synchronise an equipment, and when the original E1/DS1 signal is affected by excessive levels of wander. Although synchronization is usually distributed via the SDH or SONET transport network, there are situations where this type of synchronization cannot be

¹ It should be noted that re-timing is intended for traffic signals that are traceable to the network clock, i.e. to the Primary Reference Clock (PRC), which is also the source clock of the synchronization signal. Re-timing cannot compensate long-term frequency offsets between the traffic signal's data rate and the synchronization signal's frequency. Such frequency offsets would cause the buffer contained in the re-timing function to overflow or underflow. Data would be lost, when the buffer overflows. Data would be retransmitted when the buffer underflows. These events are called slips. Re-timing is normally used to smooth out excessive wander on synchronous PDH traffic signals.

used. If a synchronous equipment such as a switch does not feature an external timing input, then the synchronization cannot be taken from the external timing output port of the SDH/SONET network element. In such a case there is no other way than using one of the traffic-carrying E1/DS1 signals entering the switch its synchronization. A similar situation exists when the equipment to be synchronised is far away from the edge SDH/SONET multiplexer, and the only signals that get to the equipment are traffic-carrying E1/DS1 signals. This is typically the case with base stations in mobile networks. Here the only possibility is to take synchronization from one of the E1/DS1 signals.

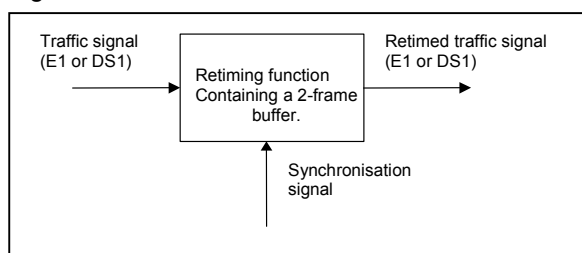

Figure 1: Elementary re-timing function.

Often traffic-carrying E1 or DS1 signals are affected by levels of wander that are acceptable for the transport of traffic, but excessive for the distribution of synchronization². If this is the case, the signals must be re-timed before they are used as synchronization signals. There are several possible causes for excessive wander (excessive in view of synchronization distribution). Either the signal source (e.g. a switch, etc.) generates too much wander, or the transport network adds too much wander. The first condition should not appear in a well-designed network. Most of the time it is the transport network which is the cause. The transport network's ability to transport client signals without degrading their timing is called "timing transparency". Timing transparency is affected by clock instabilities, by cable propagation delay variations, and by mapping processes. The next section discusses the timing transparency of SDH and SONET networks for E1 and DS1 signals.

3 Pointers in SDH and SONET

Modern transmission networks use SDH (Synchronous Digital Hierarchy) or SONET (Synchronous Optical Network) technology for

² As a matter of fact, the Network Limits for wander specified by ITU-T are different depending on whether a signal is used for traffic only or for synchronization distribution. Network Limit specifications for synchronization signals are more stringent than the specifications for pure traffic signals. Refer to ITU-T Rec. G.823 ([1]) and G.824 ([2]).

transporting traffic at data rates between 155Mbit/s (52Mbit/s for SONET) and 10Gbit/s.

SDH and SONET provide the capability of multiplexing and transporting PDH signals of any type, both from the 2'048kbit/s based hierarchy (E1, E2, E3 and E4 signals) and the 1'544kbit/s based hierarchy (DS1, DS2 and DS3 signals). This flexibility is one of the great advantages of SDH and SONET. PDH tributaries are plesiochronous. Their data rates are specified with tolerances in the order of tens of parts-per-million (e.g. ±50ppm for the 2'048kbit/s signal). SDH and SONET multiplexers can handle these data rate deviations thanks to variable pointers, which locate the beginning of a Virtual Container relative to the aggregate frame.

Data rate offsets and variations result in so-called pointer adjustments: The beginning of a Virtual Container moves step by step (in most cases one byte at a time) relative to the aggregate frame. Unfortunately pointer adjustments cause wander on the demultiplexed tributary signals that were transported over the SDH or SONET network. The Add/Drop Multiplexer that terminates the SDH or SONET path reconstructs the initial data rate of the PDH tributary signal, but adds wander in that process. The shape of that wander is a rather abrupt phase-step for each pointer adjustment event. Table 1 gives the magnitude of the phase-steps for different types of PDH tributaries. Figure 2 shows the MTIE (Maximum Time Interval Error) of the phase-step caused by a single TU-12 pointer adjustment.

Table 1: Tributary wander caused by pointer adjustments.

Tributary signal	SDH / SONET payload	Tributary wander
1'544kbit/s	VC-11	4.63µs
2'048kbit/s	VC-12	3.47µs
34.45Mbit/s	VC-3	0.16µs
139Mbit/s	VC-4	0.16µs

The table shows that the effect of pointer adjustments is particularly dramatic on DS1 (1'544kbit/s) and E1 (2'048kbit/s) tributary signals. This has led ITU-T, ETSI and Telcordia to state that E1 and DS1 tributaries transported over SDH or SONET are not suitable for synchronization. They should not be used to synchronise other Telecom equipment, because they contain wander that exceeds the relevant standards on network limits for synchronization signals¹.

As mentioned earlier, there are situations, however, where there is little alternative to taking

¹ Refer to ITU-T Rec, G.823 [1] and G.824 [2].

synchronisation from an incoming traffic-carrying E1 or DS1 signal. In such cases, re-timing eliminates the wander generated by pointer adjustments.

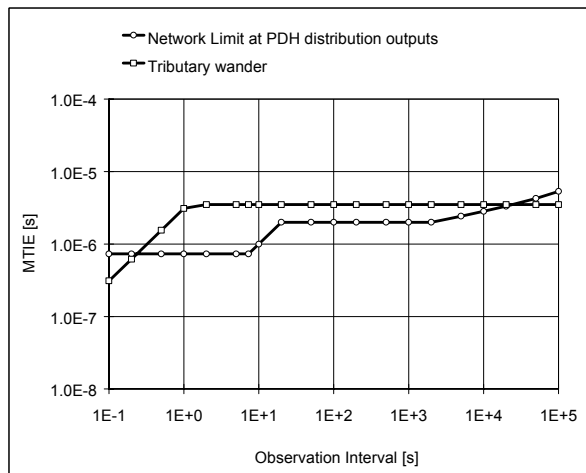

Figure 2: E1 tributary wander generated by a TU-12 pointer adjustment.

4 The Oscilloquartz Re-timing Product Line

Oscilloquartz provides a comprehensive range of products optimised for many situations, where re-timing is required.

The **Oscilloquartz Re-Timing Unit (RTU)** is a module or card that can be fitted into an existing Oscilloquartz synchronization equipment such as the OSA 5548B SASE, the OSA 5533C SDU, or the OSA 5581C GPS. An RTU can be plugged into any card location (slot) that is usually used for Output Interface Units (OIU). Each RTU module or card contains 8 elementary re-timing functions (also called re-timing channels) as shown in Figure 3.

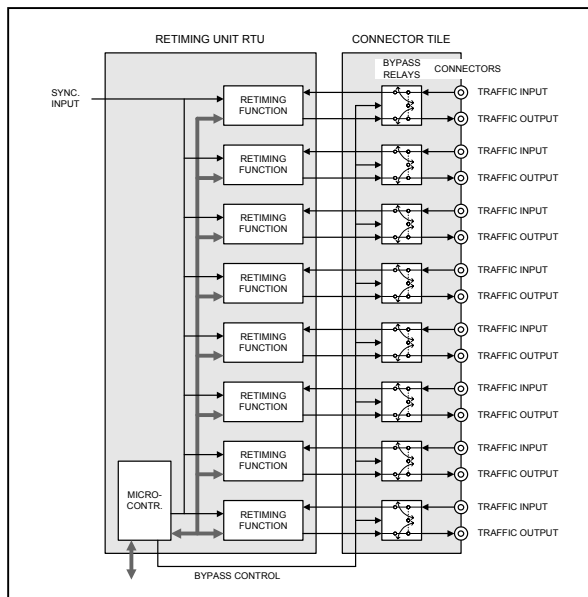

Figure 3: Block diagram of the Re-timing Unit (RTU).

An RTU is connected to a special 16-connector panel, where 8 of the 16 connectors can be used as traffic input ports, while the remaining 8 connectors become the output ports for the re-timed traffic. The RTU connector panel is equipped with relay contacts which bridge the traffic input ports to the traffic output ports in case the RTU module fails or is removed. Thus, failure or removal of an RTU module does not interrupt the traffic path. The network continues working though with degraded synchronization quality. Figure 3 shows the block diagram of an RTU and its associated connector panel. The synchronization signal is provided internally by the synchronization equipment that the RTU is part of. The OSA RTU can be fitted into any output slot of the following equipment (please see individual equipment data-sheets and booklets for further details):

- OSA 5548B SASE
- OSA 5581C GPS-SR
- OSA 5533C SDU

The **OSA 5240 GPS** is a compact rack-mountable stand-alone GPS-receiver capable of re-timing 8 to 16 E1 or DS1 traffic signals.

The **OSA 4533/4/5/6 Re-Timing Modules** are very compact (5"x4"x2") stand-alone boxes capable of re-timing a single E1 or DS1 traffic signal. They are ideal for space-critical applications such as mobile base stations and DAB/DVB/DTV transmitters.

The **OSA 4533/4 GPS** feature an internal GPS receiver that acts as timing reference; hence the out-coming E1/DS1 signal is compliant to ITU-T Rec. G.811 (when locked to GPS).

The **OSA 4535/6 RTM** take the incoming E1 or DS1 signal as reference and smooth out timing impairments from it. They are ideal for those cases where GPS antenna installation is impossible or when cost is a decisive factor. They provide a jitter and wander filtering function compliant to ITU-T Rec. G.812, Type I SSU.

5 Typical Applications

5.1 Switch without External Timing Input

Figure 4 shows a case, where a digital switch is connected to a co-located SDH or SONET Add/Drop-Multiplexer via several E1 or DS1 signals. The digital switch does not feature an external timing input. Thus the switch has to derive the synchronization from one of the incoming E1 or DS1 signals. Since these signals have traversed an SDH/SONET network, they are not suitable for the distribution of synchronization.

A Retiming Unit inserted in an OSA 5548B SASE or an OSA 5581C GPS-SR solves the problem. Synchronization signals derived from the SDH/SONET line signals are usually of good quality. Hence they can be used to re-time the traffic-carrying E1 or DS1 signal. This is done by connecting the synchronization signal provided by the SDH/SONET ADM's external timing output to the Oscilloquartz equipment, where it then controls the re-timing buffer. Alternatively the re-timing buffer can also be controlled by a GPS-receiver module present in the OSA 5581C GPS-SR or the OSA 5548B SASE. Both the SDH/SONET-derived synchronization signal and the GPS are suitable synchronization sources.

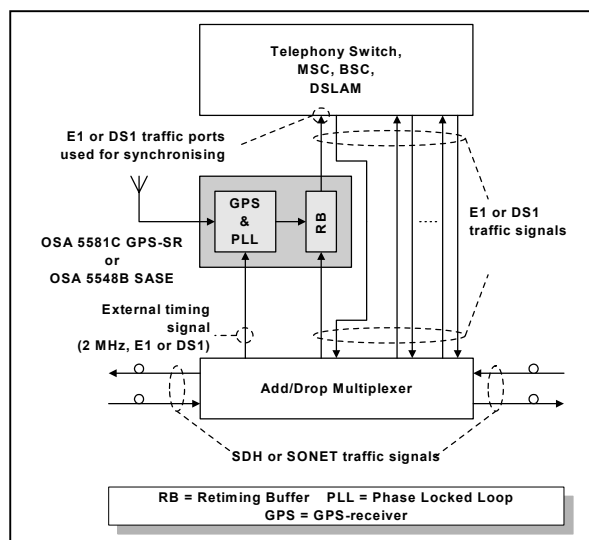

Figure 4: Re-timing used for synchronising a digital switch.

This situation applies not only to telephony switches, but to any kind of synchronous equipment such as MSC (Mobile Switching Center), BSC (Base Station Controller), RNC (Radio Network Controller), etc.

5.2 Base Station or Node B

Figure 5 shows the case of a base station¹ in a mobile network. The base station is connected to the core network via E1 or DS1 traffic signals. These signals are transported over the SDH or SONET network, which they leave at the edge ADM. The edge ADM is co-located with the base station. It is impractical to synchronise the base station to the ADM's external timing output, since this would require a dedicated transmission cable between the ADM site and the base station. The solution is again re-timing. A re-timing equipment (e.g. OSA 5533C SDU or OSA 5548B SASE) co-located with the ADM and controlled by the ADM's external timing output imprints synchronization onto

¹ In GSM networks, a base station is also called a Base Transceiver Station or BTS. In UMTS networks, a base station is also called a "Node B".

one several (redundancy!) of the E1/DS1 signals. This way both traffic and synchronization is transmitted from the ADM to the base station over the same transmission cable.

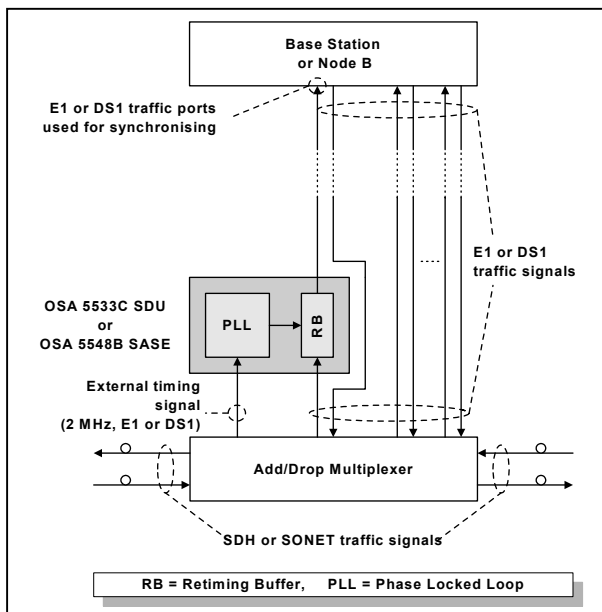

Figure 5: Re-timing used for synchronising a base station.

The situations in Figure 4 and Figure 5 are similar. In both cases the synchronous equipment (switch, base station, etc.) cannot take synchronization from the ADM's external timing output. In both cases the traffic-carrying E1/DS1 signals are not suitable for distributing synchronization because they traversed an SDH/SONET network. In both cases the solution consists in re-timing one or several E1/DS1 signals so that they take on synchronization derived from the SDH/SONET network.

5.3 Problematic Transport Networks

In the two cases presented above, there is an SDH or SONET network element which delivers (over the external timing output port) PRC-traceable synchronization. In the case discussed in this section, the transport network does not provide trustworthy synchronization. There are many possible reasons why an operator chooses not to trust the synchronization coming from the transport network. A typical example is that of a mobile operator relying on a 3rd party operator for transport services. If there is no contract or agreement on synchronization quality, availability, and signaling between the two operators, the mobile operator may decide not to trust the synchronization derived from the transport network.

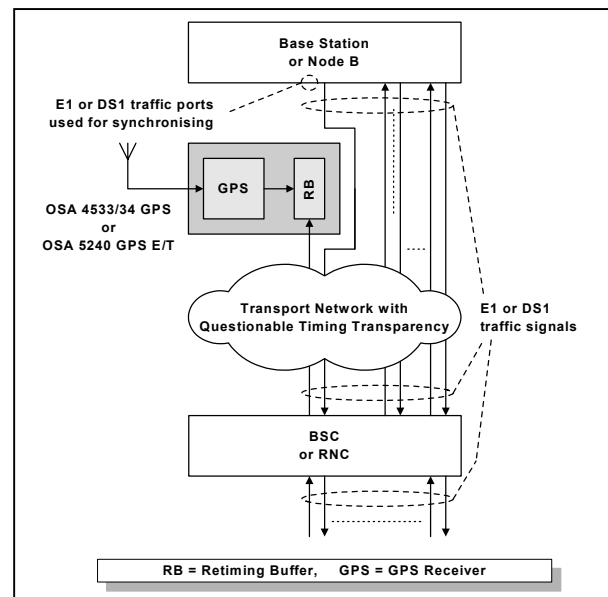

Figure 6: Base station synchronised by the GPS.

Figure 6 shows how a GPS receiver equipped with a re-timing buffer solves the problem. Here the base station is synchronized to the GPS-receiver. Because there is no external timing input port on the base station, one of the E1 or DS1 traffic signals is re-timed., thus conveying GPS-traceable synchronization to the base station.

Figure 7 shows a somewhat different solution. Here synchronization is not derived from the GPS, but from the E1/DS1 signal itself. These signals are generated by the BSC (Base Station Controller) or the RNC (Radio Network Controller). BSC and RNC are always synchronized to a PRC (at least under normal operating conditions, i.e. in the absence of synchronization failures). This means that the E1/DS1 signals they generate are synchronous (i.e. within Network Limits for synchronous traffic signals). The transport network degrades the timing by adding jitter and wander. However the transport network does not degrade the long-term frequency accuracy of the E1/DS1 signals. All that needs to be done is to remove the excessive jitter and wander by appropriate filtering. This is achieved with a narrow-bandwidth PLL (Phased Locked Loop) locked to the signal itself. The output of the PLL then drives the re-timing buffer. The system causes jitter and wander of the E1/DS1 signals to be smoothed out.

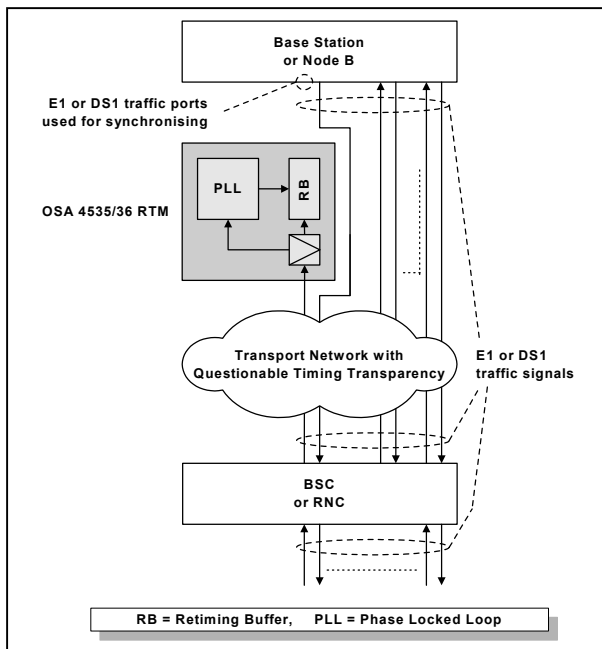

Figure 7: Base station synchronised by regenerated E1 or DS1 signals

This technique is only applicable in cases where the level of wander is within the regenerating capability of the PLL. In cases where the wander level exceeds this capability, the previously discussed solution with GPS-receiver must be used.

Figure 8 illustrates the regenerating capability of a PLL with a bandwidth of 3 mHz. The lower MTIE curve corresponds to the Network Limit for PDH synchronization interfaces according to ITU-T Rec. G.823, § 6.2.4 [1]. This Network Limit is the maximum wander that synchronous equipment such as switches, base stations, DSLAM, etc. (except SDH and SONET network elements¹) can accept on their synchronization input ports. The upper MTIE curve shows the maximum wander that the 3 mHz PLL can regenerate, so that it falls below the targeted Network Limit (lower curve).

6 Economics

Dropped calls in a GSM network depend on several parameters. Two important parameters are the traffic load in the radio access network and the synchronization quality at the base station's transmitter antenna. In a network with medium to high traffic load and sub-optimal synchronization, the rate of dropped calls can be improved in two ways. The first alternative is to improve the traffic capacity of the radio access network by deploying more base stations. This

¹ SDH and SONET network elements require synchronization signals complying at least with Network Limits for SEC outputs according to ITU-T Rec. G.823, § 6.2.3 (SDH), or G.824, § 6.2.2 (SONET).

solution is very costly. The second alternative is to improve synchronization quality by implementing re-timing solutions. A field trial run by a large European GSM operator demonstrated a substantial reduction in dropped calls after the introduction of a re-timing solution for the BSC synchronization (GPS-based re-timing, as in Figure 4). Cost calculations showed, that it was much more cost-effective to obtain the targeted improvement in dropped calls by the deployment of re-timing equipment than by the deployment of additional base stations.

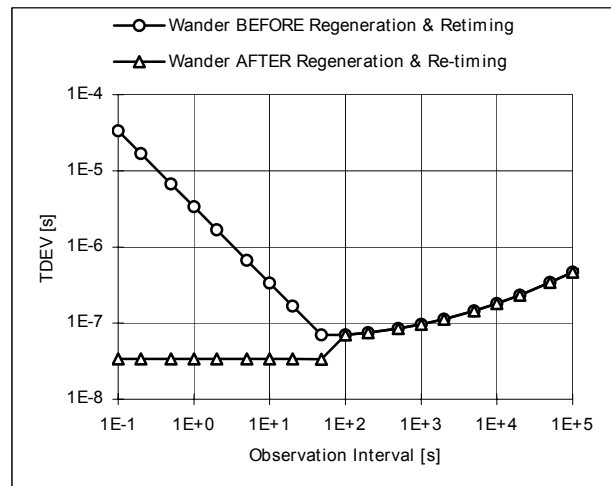

Figure 8: Regenerating capability of a 3 mHz PLL

7 Conclusion

In a perfect world synchronization should be as easy as connecting all nodes of a network to a central Primary Reference Clock. However, as a consequence of the de-regulation of telecom markets, communications links often traverse several synchronization domains. The resulting interfacing problems can often be solved by the use of re-timed E1 or DS1 traffic signals. Oscilloquartz provides a comprehensive range of re-timing products. The applications cases shown in section 5 show implementation details of typical re-timing solutions. An important point to be considered is the cost factor: implementing a re-timing solution is often much more cost-effective than correcting the situation in other ways.

8 Bibliography

- [1] International Telecommunications Union; ITU-T Recommendation G.823: The control of jitter and wander within digital networks which are based on the 2048 kbit/s hierarchy; Geneva; March 2000.
- [2] International Telecommunications Union; ITU-T Recommendation G.824: The control of jitter and wander within digital networks which are based on the 1544 kbit/s hierarchy; Geneva; March 2000.

- [3] ETSI; EG 201 793: Transmission and Multiplexing, Synchronization Network Engineering; April 2000 ; Sophia Antipolis.

9 Abbreviations

Table 2: Abbreviation used in this document.

ADM	Add/Drop Multiplexer
BTS	Base Transceiver Station
CTO	Compact Tracking Oscillator
DS1, DS2, DS3	Definition of the Virtual containers used in the Synchronous Optical Network
DXC	Digital Cross-connect
E1, E2, E3, E4	Definition of the Virtual containers used in the Synchronous Digital Hierarchy
ETSI	European Telecommunication Standard Institute
ITU-T	International Telecommunication Union – Telecommunication
OIU	Output Interface Unit
PDH	Plesiochronous Digital Hierarchy
RTU	Re-Timing Unit
SASE	Stand Alone Synchronization Equipment
SDH	Synchronous Digital Hierarchy
SDU	Synchronization Distribution Unit
SONET	Synchronous Optical Network