



**OSCILLOQUARTZ**

A COMPANY OF THE SWATCH GROUP

---

# Application Note

Number 07/96

Updated 17.08.98

---

## Applications of the Stand-Alone Synchronisation Equipment in optical networks and the Synchronous Digital Hierarchy (SDH)

## INTRODUCTION

Synchronous Digital Hierarchy (SDH) is a new international standard for transmission, agreed by the ITU-T in 1988.

It is developed from Synchronous Optical Networks (SONET) previously defined by ANSI.

Both SONET and SDH are designed to carry Plesiochronous Digital Hierarchy (PDH), and future transmission signals like Asynchronous Transfer Mode (ATM).

A significant advantage of SONET/SDH over PDH is that the asynchronous traffic signals can be directly dropped/inserted at any level of the multiplexing hierarchy without any intermediary multiplexing and demultiplexing equipment.

Additionally the network synchronisation signal can be directly retrieved at any level of the SONET/SDH hierarchy.

To compensate the phase and frequency differences between the asynchronous input signals and the SONET/SDH equipment, a pointer adjustment mechanism is used as defined in ITU-T G.70x.

The input signals are mapped into Virtual Containers (VCs), which are allowed to float within Tributary Units (TUs).

The SONET/SDH pointers simply indicate the start of the VC byte within a TU on a per 125us frame basis.

However, each pointer action introduces low phase/frequency variation (wander) to the associated traffic signal, and therefore it is not recommended to transport synchronisation via the asynchronous tributary interfaces of the SONET/SDH equipment.

## SONET/SDH NETWORK SYNCHRONISATION

To minimise the occurrence of the pointer actions, and to maintain the performance of the SONET/SDH network, it is necessary to slave all the G.81s Synchronous Equipment Clocks (SECs) to one G.811 master clock, or a number of G.811 master clocks. To filter the systematically accumulated SEC noise in the synchronisation chains, A G.812 clock or Stand Alone Synchronisation Equipment (SASE) is required after every twenty (or less) consecutive SECs. The SASE is also used to select an alternative synchronisation input when the active input fails, and act as a secondary master clock when the master clock or when the connections to the master clock fails. Additionally it is necessary to limit the number of SECs and SASEs in the SDH synchronisation trails, as detailed in ITU-T G.803 and as shown in figure 1.

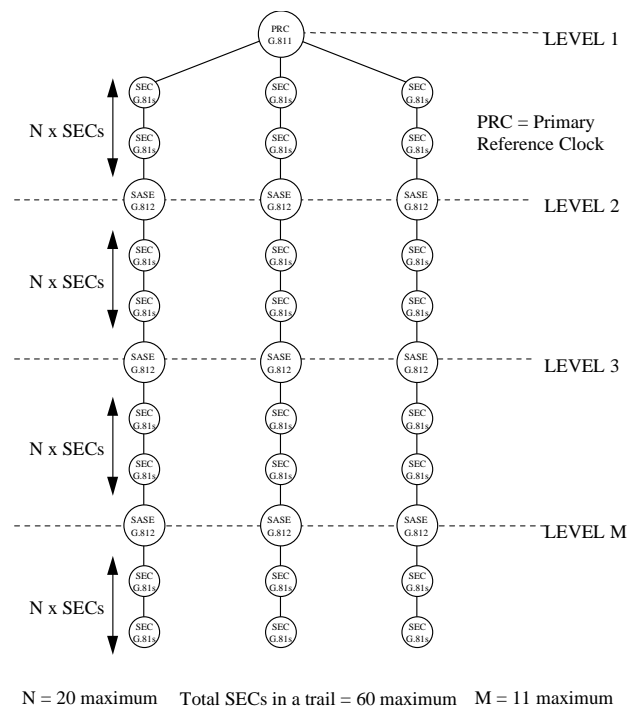

Figure 1: Synchronisation network reference trails

The synchronisation levels 2 to 11 can be grouped into three network layers, as shown in figure 2. The thick lines show that the clocks are connected together, and the thin lines show the standby synchronisation trails.

The SASEs in the national and regional layers are required to meet the performance specified in ITU-T G.812 for the transit clock, and the SASEs in the local layer are required to meet the performance specified in ITU-T G.812 for the local clock.

Additionally, it is necessary to source each SASE with two or more synchronisation trails, that are traceable to the Primary Reference Clock (PRC), to increase the availability of the synchronisation network.

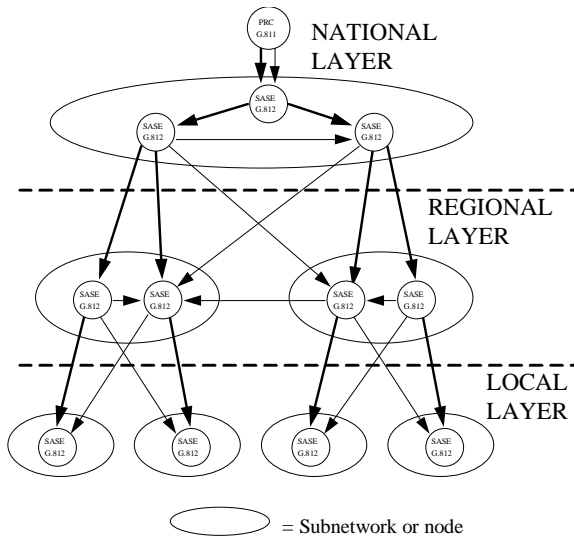

Figure 2 : Centralised synchronisation network architecture

Alternatively, a (large) number of PRCs can be distributed in the SONET/SDH network to eliminate the national and regional synchronisation layers as shown in figures 3 and 4.

Additionally the PRCs shown in these figures can be replaced by Global Positioning System (GPS) timing receivers, or other timing sources meeting the ITU-T G.811 specification.

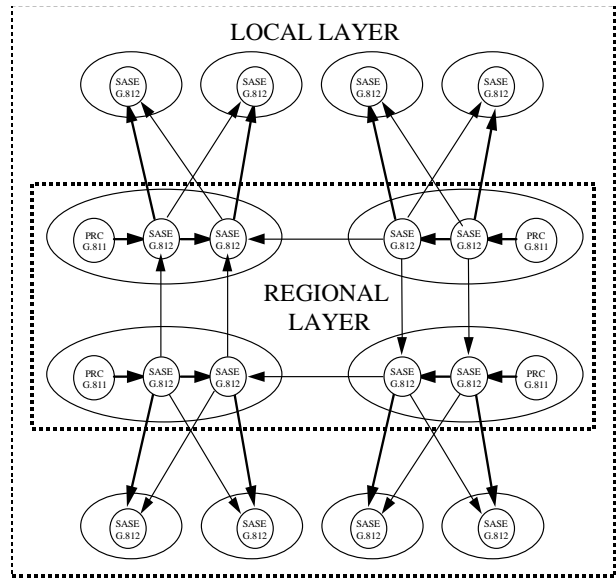

Figure 3 : Distributed synchronisation network architecture

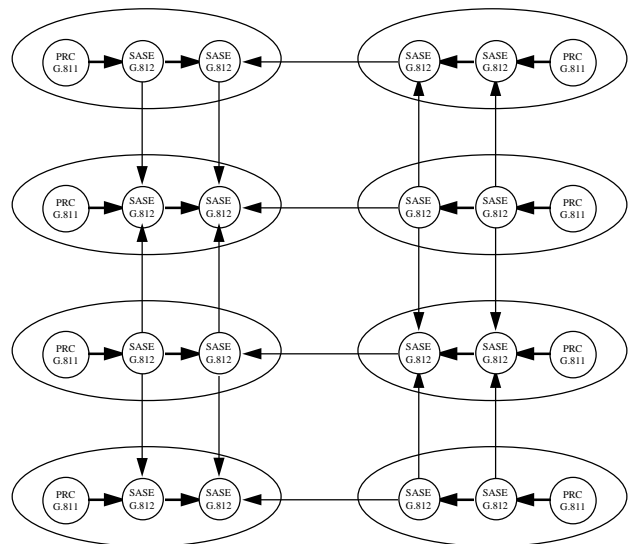

Figure 4 : Distributed synchronisation subnetworks

**NODE SYNCHRONISATION**

The SASE is designated as the node clock, as detailed in ITU-T G.803 and as shown in figure 5. The node boundary can be a rack, a room, a building floor, a building or an area. Generally the node boundary is confined to a building, and the SASE is therefore sometimes referred to as the Building Integrated Timing Source (BITS).

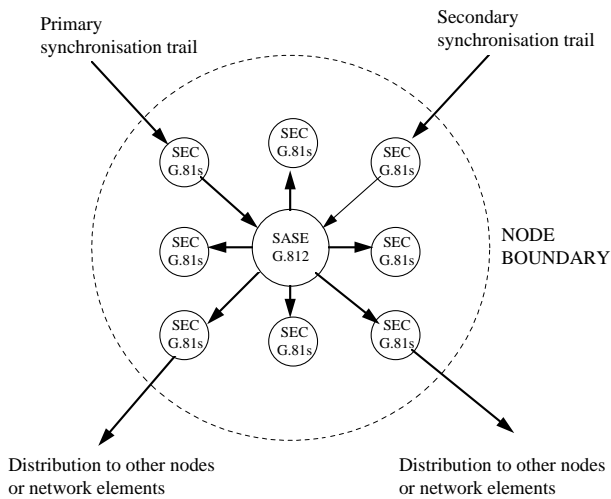

Figure 5 : Synchronisation network architecture intra-node distribution

An example synchronisation plan of a SONET/SDH node is shown in figure 6. Each network element is fed by two synchronisation signals from the SASE, to increase the availability of the intra-node synchronisation. Additionally, the two synchronisation signals should be derived from different output cards on the SASE.

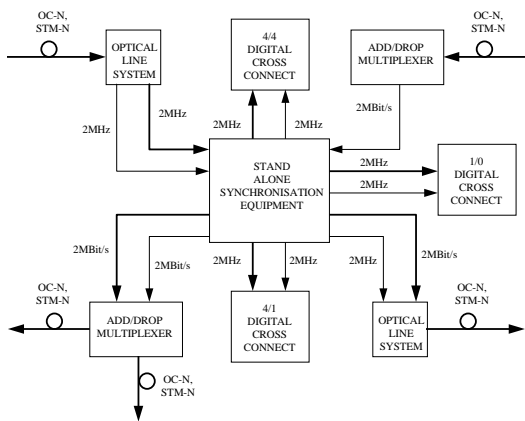

Figure 6 : Network element intra-node synchronisation

**RING/CHAIN SYNCHRONISATION**

An intermediary SASE is required if the number of NEs in a SONET/SDH ring subnetwork or a NE chain is greater than twenty, in accordance to ITU-T G.803. In this application, the SASE is synchronised from the T4 [non Synchronous Equipment Timing Generator (SETG) locked] output of the NE, and then source the T2 and/or T3 inputs of the NE, as shown in figure 7.

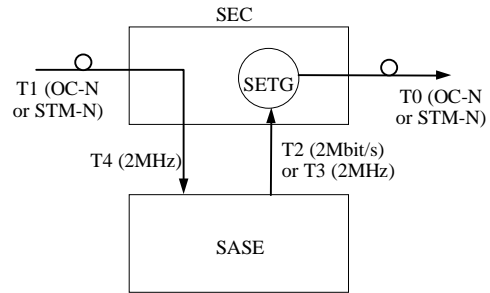

Figure 6 : Intermediary SASE in a large ring or a long chain of NEs

**DEPLOYMENT OF THE SONET/SDH SYNCHRONISATION NETWORK**

The deployment of the SONET/SDH synchronisation network is dependent on a number of factors.

New network operators can deploy their SDH synchronisation network from the beginning. However, as their networks could be initially small and segmented, the construction of the full SDH synchronisation network would require a number of deployment phases.

Most of the established network operators, however, have already constructed a resilient PDH synchronisation network, and changing it to a SDH synchronisation network could be too expensive and problematic. Additionally the migration of the PDH network synchronisation plan to the SDH network synchronisation plan would require a number of deployment phases, because of the phased construction of the SDH transmission network. In some cases, the SDH (sub)networks may be initially synchronised by the PDH synchronisation network.

An alternative synchronisation strategy for the network operators is to deploy a separate synchronisation network layer, to synchronise various telecommunication networks as shown in figure 7.

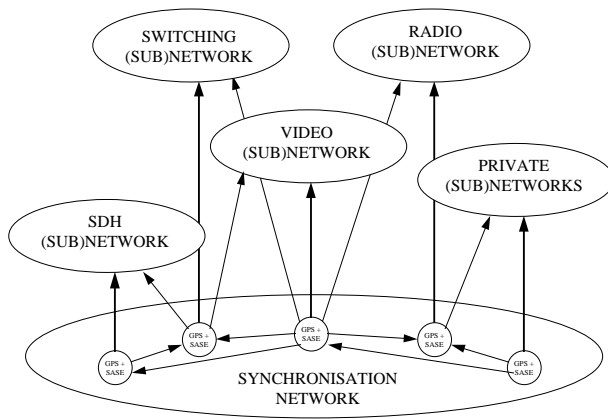

Figure 7 : Separate synchronisation network layer

## REFERENCES

- |             |   |
|-------------|---|
| ITU-T G.70x | Network node interface for the synchronous digital hierarchy  |
| ITU-T G.803 | Architectures of transport networks based on the Synchronous Digital Hierarchy  |
| ITU-T G.813 | Timing characteristics of slave clocks suitable for operation of SDH equipment  |
| ITU-T G.754 | Fourth order digital multiplexing equipment operating at 139264 Kbit/s  |
| ITU-T G.811 | Timing requirements at the outputs of primary reference clocks suitable for plesiochronous operation of international digital links |
| ITU-T G.812 | Timing requirements at the outputs of slave clocks suitable for plesiochronous operation of international digital links             |