



OCXO 8863 Double oven controlled 19mm (0.75")

Oven Controlled Crystal Oscillator

The **8863** series offer excellent frequency stability in very low volume and very low profile package.

The thermal design with down to 2×10^{-10} pp stability over temperature range, makes this device unique for severe holdover requirements.

Features

- SC cut 3rd overtone crystal resonator
- Wide operating temperature range (-20°C to 70°C)

Benefits

- Selectable long term stability
- Easily interfaces with analog or digital circuits
- Fits all telecommunications requirements

Applications

- Precise time keeping and navigation equipment: **GPS/GSM/UMTS/CDMA**
- Stratum II & III
- Base station

Pin to pin compatible with 886x models.

Outline and Electrical connections

All dimensions in mm (inches)
Surface mount technology on study

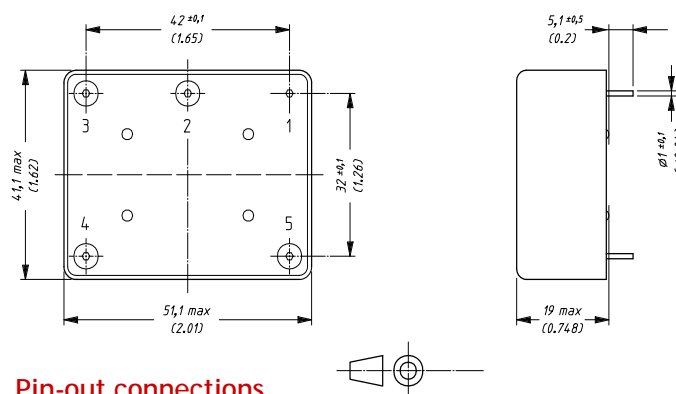

Pin-out connections

- 1: GND
- 2: Vc input
- 3: Vref out
- 4: +Power supply
- 5: Output

Phase noise L (f) (BW = Hz)		
Frequency		10 MHz
Phase noise	1Hz	- 95 dBc
	10 Hz	- 130 dBc
	100 Hz	- 140 dBc
	1k Hz	- 150 dBc
	10k Hz	- 155 dBc
	100k Hz	- 155 dBc

Ordering Information

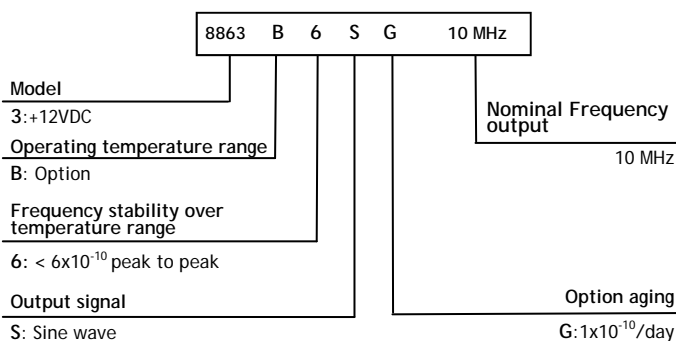

Technical Specifications

OCXO 8863

Oven Controlled Crystal Oscillator

Standard / Option	Standard		Option	
Crystal Oscillator	SC-cut			
Standard frequencies	4.096/5/8.192/10/16.384 MHz		4.096 to 40 MHz	
Operating temperature range	A: -20°C to +70°C		B: 0°C to +70°C C: 0°C to +60°C	
Frequency stability ($\Delta f/f$)	Standard	Option G	Option H	Option J
Long term stability Aging after 30 days of continuous operation : Applicable for :	2x10 ⁻¹⁰ /day 3x10 ⁻⁸ /year 30 days 4.096 to 40MHz	1x10 ⁻¹⁰ /day 2x10 ⁻⁸ /year 30 days 4.096 to 40MHz	5x10 ⁻¹¹ /day 1.5x10 ⁻⁸ /year 60 days 4.096 to 10MHz	3x10 ⁻¹¹ /day 1x10 ⁻⁸ /year 90 days 4.096 to 10MHz
Over temperature range (Y)	Std: < 1x10 ⁻⁹ peak to peak		2: < 2x10 ⁻¹⁰ peak to peak 6: < 6x10 ⁻¹⁰ peak to peak	
Versus supply voltage changes (Vcc ±5%)	< ±3x10 ⁻¹⁰			
Versus load changes (50Ω ± 10%)	< ±5x10 ⁻¹¹			
Short term stability $\sigma(\tau)$ 1s to 10s	< 1x10 ⁻¹¹			
Electronic frequency control	>± 0.3 ppm (0 to 10 Volts) / Linearity<10% / Positive slope			
Power Supply (P)				
Input voltage range (DC)	+12 Volts ± 5%			
Power consumption (@Vcc = 12V)	< 9W during warm up / < 2.5W after warm-up at +25°C			
Environment (Not operating)				
Storage temperature	-40°C to +125°C			
Vibration	MIL-STD 176-1			
Shock	50g, 11ms, 3 shocks in each direction of the main axis			
Size (L x W x H)	51.1 x 41.1 x 19mm (2.01" x 1.62" x 0.75")			
Weight	~ 63g			
Outline and electrical connections	See drawing page 1			
Outputs Characteristics (Z)	S			
Wave form	Sine (square wave: consult factory)			
Level (Tol.) / Impedance	> +4 dBm / 50Ω			
Phase noise	See table page 1			
Harmonics	< -30 dBc			
Spurious in the frequency range up to 1 MHz	< -80 dBc			
Symmetry	Not applicable			
Rise/Fall time (10/90% 1xHCMOS gate)	Not applicable			
Internal reference voltage				
Pin 3: Vref out (R _{Load} >20kΩ)	8 Volts ± 0.2 Volt (source resistor 1kΩ)			

Oscilloquartz SA reserves the right to change all specifications contained herein at any time without prior notice.

www.oscilloquartz.com

