

OSA 5051/5052 Dual Switch

A compact, cost efficient, high quality Dual Switch

Introduction

The 5051/5052 Dual Switch Unit is mainly designed for time and frequency applications where reliability criteria call for redundancy in RF and Pulse source.

This unit accepts two input pairs consisting of one RF signal (sine/square) and one pulse (typically 1PPS).

Both primary and secondary pairs are monitored and in case of fault, the unit will automatically switch to the other channel (Typically switching <3ms).

In addition, OSA 5051 or 5052 offers local or remote control using RS-232 or Ethernet interface.

Input/Output range is from 1MHz to 20MHz for RF signal and from 0.1s to 2s for the pulse signal.

Typical Applications

- Time and frequency distribution system
- Any system requesting frequency and square wave switching



Highlights

- Reliable, compact
- Dual input frequency and PPS
- Fast switching time (<3ms typical)
- Fast RF option switching time @ 1.0ms.
- 2x 8 outputs (expandable up to 2x12)
- BNC connectors for all inputs and outputs
- AC or DC power supply
- Local or remote control

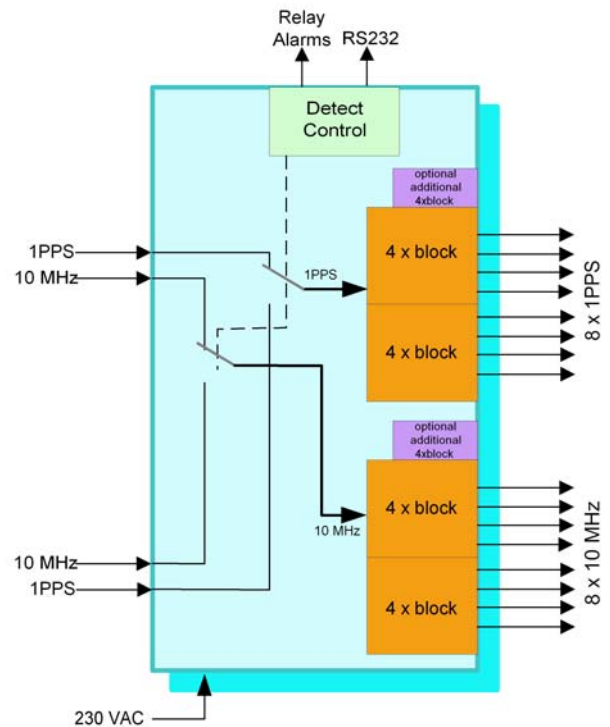

OSA 5051/5052 Dual Switch

A compact, cost efficient, high quality Dual Switch

Typical Characteristics

Channel A:

- RF Input: 1MHz to 20MHz sine wave
13 dBm (1Vrms nominal)
- Pulse Input: 0.5 to 10Hz
5V CMOS into 50 ohms

Channel B:

- RF Input: 1MHz to 20MHz sine wave
13 dBm (1Vrms nominal)
- Pulse Input: 0.5 to 10Hz
5V CMOS into 50 ohms

Power supply:

- AC Power supply: 90 to 264 VAC (47 – 63 Hz)
- Optional DC PSU: 48VDC (20–70 VDC)

Configuration and monitoring:

- Local via RS232, Remote via Ethernet (SNMP or HTTP) control, or front panel channel selection.
- Alarms on relay contacts

Outputs (Same as Selected input signal):

- RF : 1MHz to 20MHz sine wave
13 dBm (1Vrms nominal)
- Pulse : 0.5 to 10Hz
5V CMOS into 50 ohms

Switching:

- Switching time: Typical 3ms
- Switching type Relay contact switching
- Switching control: Auto/Remote/Local
- Fast RF option: Switching time $\approx 1.0 \mu\text{s}$

Mechanical:

- Mounting: 19" rack mount
- Size: **1** 43 x 484 x 310 mm (1U x 19" x 12")
2 89 x 484 x 310 mm (2U x 19" x 12")
(Depending on number of outputs)
- Weight: $\sim 5\text{kg}$ excluding packing
- Connector access: Rear

Environmental characteristics:

- Operating temperature: 0 to 50°C
- Storage temperature: -10° to +60°C
- Humidity: 0 to 95% non condensing

1 OSA 5051 / **2** OSA 5052

Oscilloquartz SA reserves the right to change all specifications contained herein at any time without prior notice.

 A COMPANY OF THE SWATCH GROUP

